

Jul.1.2020 Copyright 2020 HIROSE ELECTRIC CO., LTD. All Rights Reserved.
 In case of consideration for using Automotive equipment / device which demand high reliability, kindly contact our sales window correspondents.

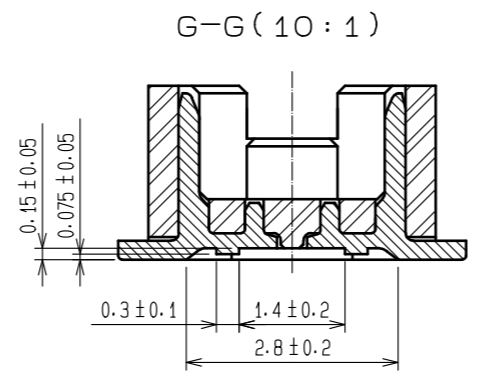

CODE NO.	CONTACT	A	B	C	D	E	F
CL537-0756-4-86	10	4.7	2.0	2.8	3.2	2.8	5.6
CL537-0919-7-86	14	5.7	3.0	3.8	4.2	3.8	6.6
CL537-0758-0-86	20	7.2	4.5	5.3	5.7	5.3	8.1
CL537-0760-1-86	30	9.7	7.0	7.8	8.2	7.8	10.6
CL537-0767-0-86	32	10.2	7.5	8.3	8.7	8.3	11.1
CL537-0761-4-86	36	11.2	8.5	9.3	9.7	9.3	12.1
CL537-0762-7-86	40	12.2	9.5	10.3	10.7	10.3	13.1
CL537-0764-2-86	50	14.7	12.0	12.8	13.2	12.8	15.6
CL537-0766-8-86	60	17.2	14.5	15.3	15.7	15.3	18.1
CL537-0768-3-86	80	22.2	19.5	20.3	20.7	20.3	23.1

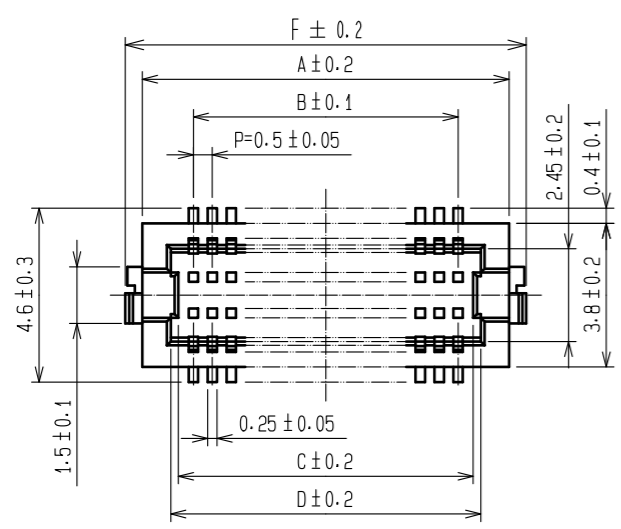
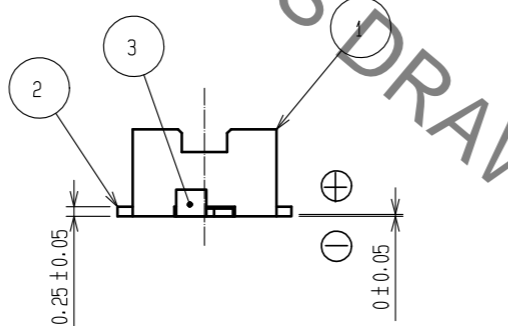
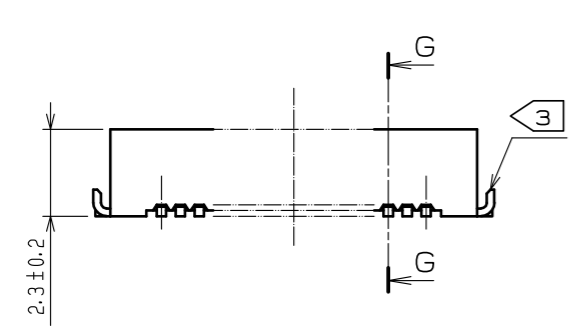

RECOMMENDED METAL MASK PATTERN (10:1)

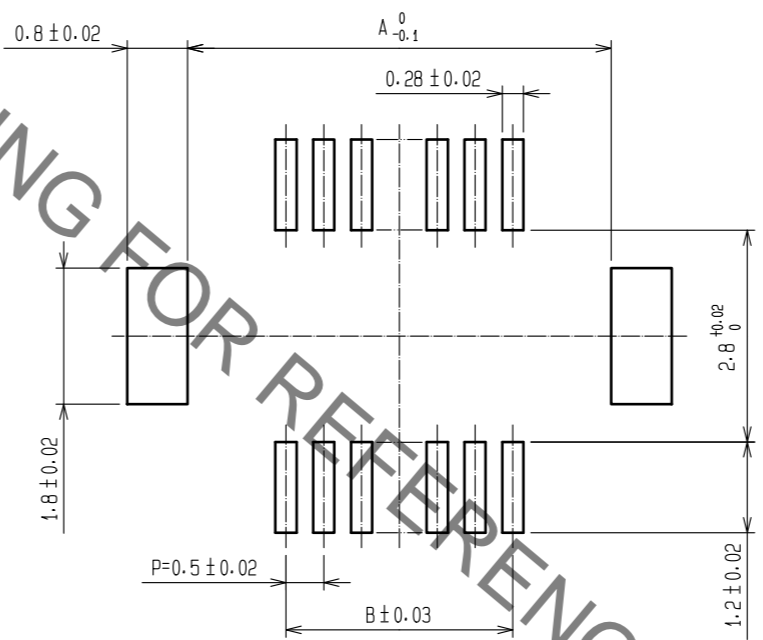

RECOMMENDED PATTERN (10:1)

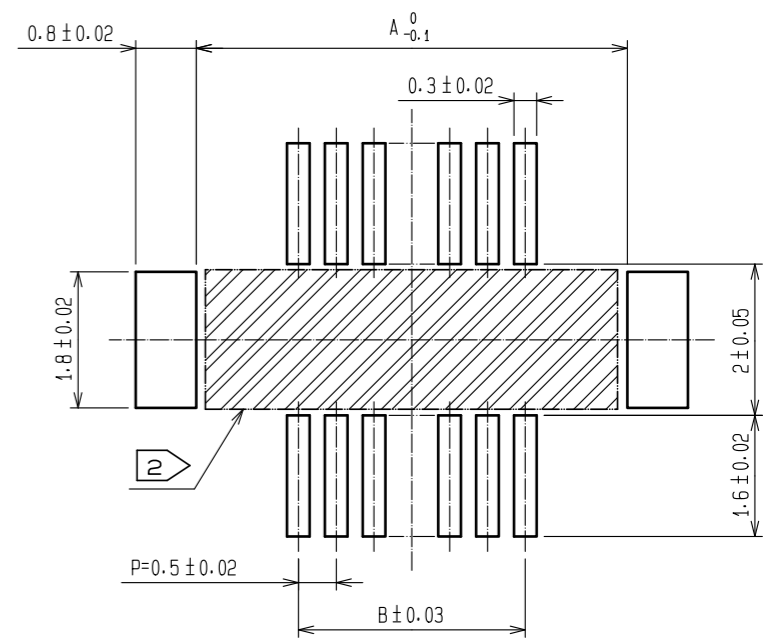

RECOMMENDED THICKNESS OF METAL MASK: 120µm

RECOMMENDED THICKNESS OF SOLDER PASTE: 120µm

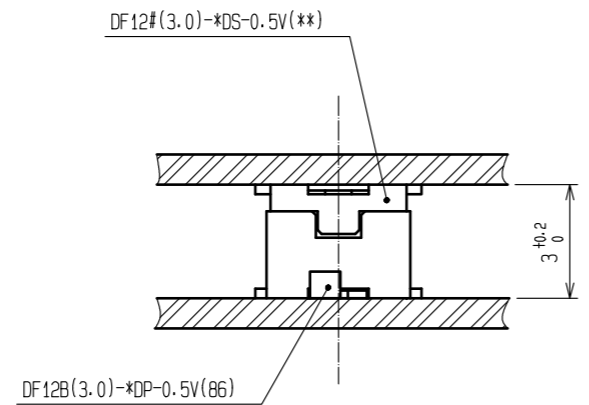
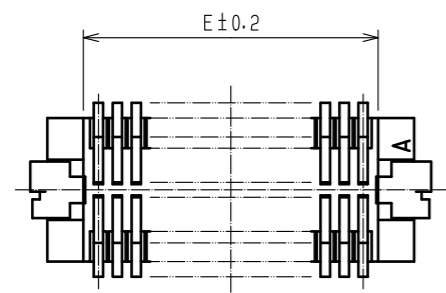

- NOTES 1 LEAD CO-PLANARITY INCLUDING REINFORCED METAL FITTINGS SHALL BE 0.08 mm MAX.
 2 IF THERE IS PATTERN ON PART, THERE IS A POSSIBILITY THAT IT WILL MAKE CONTACT WITH THE LEADS.
 3 REINFORCED METAL FITTINGS AS FOLLOWS.

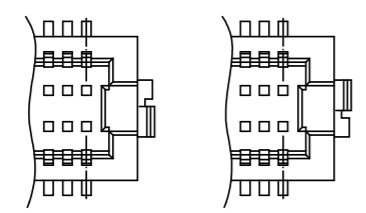

NO.	MATERIAL	FINISH . REMARKS	NO.	MATERIAL	FINISH . REMARKS
2	PHOSPHOR BRONZE	CONTACT AREA:GOLD PLATED 0.2µm min LEAD AREA:GOLD PLATED 0.015µm min OTHERS(UNDER PLATING):NICKEL 2µm min	7	PS	CLEAR(REINFORCEMENT COLLAR)
1	POLYAMIDE	BEIGE, UL94V-0	6	PS	BLACK(PLASTIC REEL)
			5	POLYESTER	CLEAR(COVER TAPE)
			4	PS	CLEAR(EMBOSSED CARRIER TAPE)
			3	BRASS	TIN PLATED 2µm min UNDER PLATING:NICKEL 1µm min

UNITS	SCALE	COUNT	DESCRIPTION OF REVISIONS	DESIGNED	CHECKED	DATE
mm	5 : 1	△				

APPROVED	: WR. FUKUCHI	20190409	DRAWING NO.	EDC-160780-86-78
CHECED	: WR. FUKUCHI	20190409	PART NO.	DF12B(3.0)-*DP-0.5V(86)
DESIGNED	: KT. KUSAKA	20190409	CODE NO.	CL537
DRAWN	: RN. IIDA	20190409		

Jul.1.2020 Copyright 2020 HIROSE ELECTRIC CO., LTD. All Rights Reserved.
 In case of consideration for using Automotive equipment / device which demand high reliability, kindly contact our sales window correspondents.

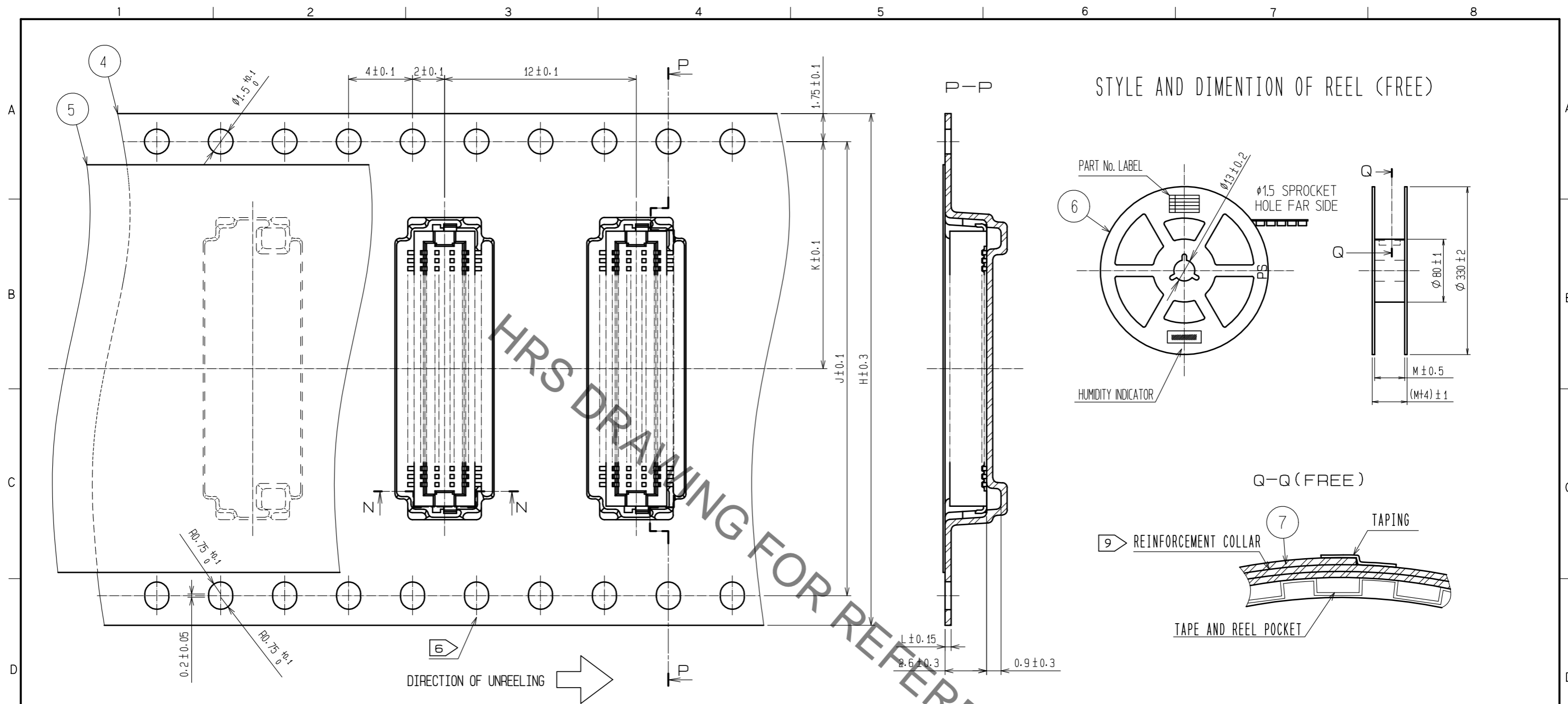

STYLE AND DIMENTION OF REEL (FREE)

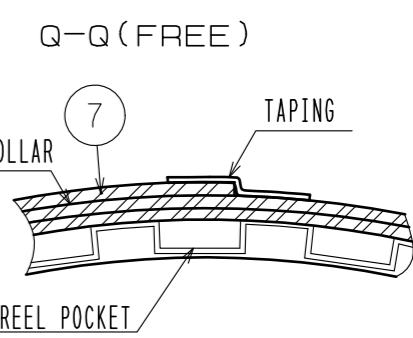
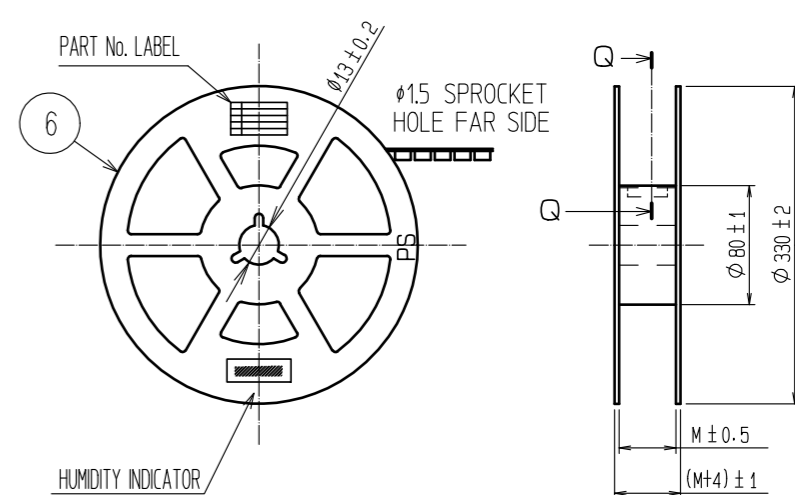

CODE No.	CONTACT	H	J	K	L	M
CL537-0756-4-86	10	16	-	7.5	0.30	17.5
CL537-0919-7-86	14	16	-	7.5	0.30	17.5
CL537-0758-0-86	20	16	-	7.5	0.38	17.5
CL537-0760-1-86	30	24	-	11.5	0.38	25.5
CL537-0767-0-86	32	24	-	11.5	0.30	25.5
CL537-0761-4-86	36	24	-	11.5	0.38	25.5
CL537-0762-7-86	40	24	-	11.5	0.38	25.5
CL537-0764-2-86	50	24	-	11.5	0.38	25.5
CL537-0766-8-86	60	32	28.4	14.2	0.38	33.5
CL537-0768-3-86	80	44	40.4	20.2	0.38	45.5

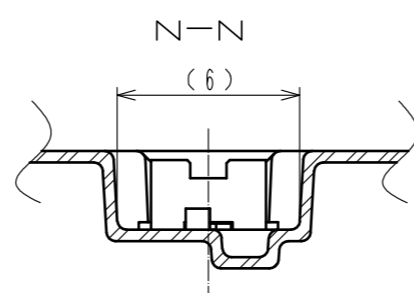

- NOTES
- 4 1 REEL 1000 CONNECTORS.
 - 5 AT THE BEGINNING OF THE REEL, 30 COMPONENTS SHALL BE EMPTY. AT THE END OF THE REEL, 20 COMPONENTS SHALL BE EMPTY.
 - 6 WHEN THE TAPE WIDTH IS 32 mm OR 44mm, SPROCKET HOLES SHALL BE SET ON BOTH SIDE OF REEL AS SHOWN ON THIS DRAWING.
 - 7 PEEL FORCE REFERS TO JIS C 0806. (IEC 60286-3)
 - 8 SPECIAL PACKING IS APPLIED FOR THIS PRODUCT, USING POLYAMIDE RESIN, TO IMPROVE MOISTURE RESISTANCE. AFTER OPENING AND WHEN RESTORING IS NEEDED, PLEASE PUT THE PRODUCT WITH DESICCANT IN A SEALED ALUMINIUM BAG. IN CASE THE COLOR OF THE INDICATOR(30%) TURNED TO PINK, DO BAKING THE PRODUCTS(50°C, 48HOURS).
 - 9 AFTER PACKING, ROLL 2 METERS OF THE REINFORCEMENT COLLAR TO OUTER CIRCUMFERENCE OF TAPE AND REEL POCKET, AND TAPE DOWN AT THE END THE COLLAR.

HRS	DRAWING NO.	EDC-160780-86-78
	PART NO.	DF12B(3.0)-*DP-0.5V(86)
	CODE NO.	CL537